

GRAVITY LATCH EASY INSTALLATION GUIDE



IMPORTANT: DO NOT INSERT KEY INTO LOCK UNTIL INSTALLATION IS COMPLETE

1. Latch Bracket Orientation

To change left or right orientation slide out bracket and flip over

- A** Pull and hold knob
- B** Push in spigot
- C** Slide out bracket

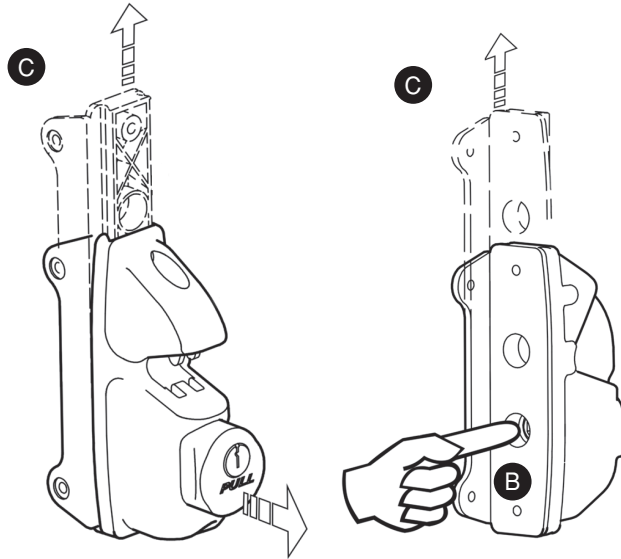

2. Latch Bracket Fitting

- D** Screw pre-drilled fixing holes

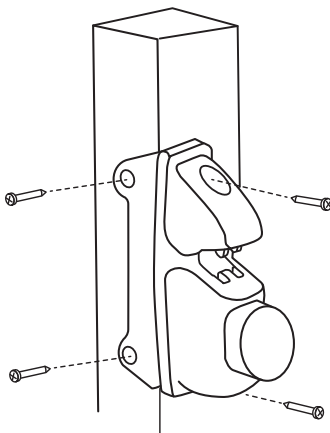

3. Striker bracket position

- E** Latch
- F** Striker bracket

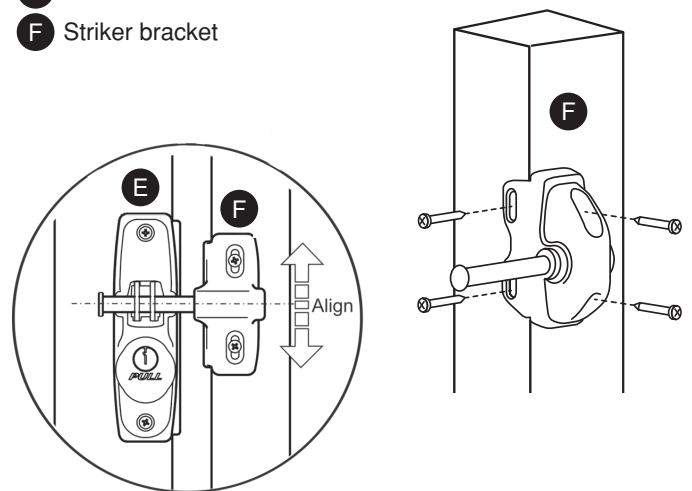

4. Check latch is operating correctly

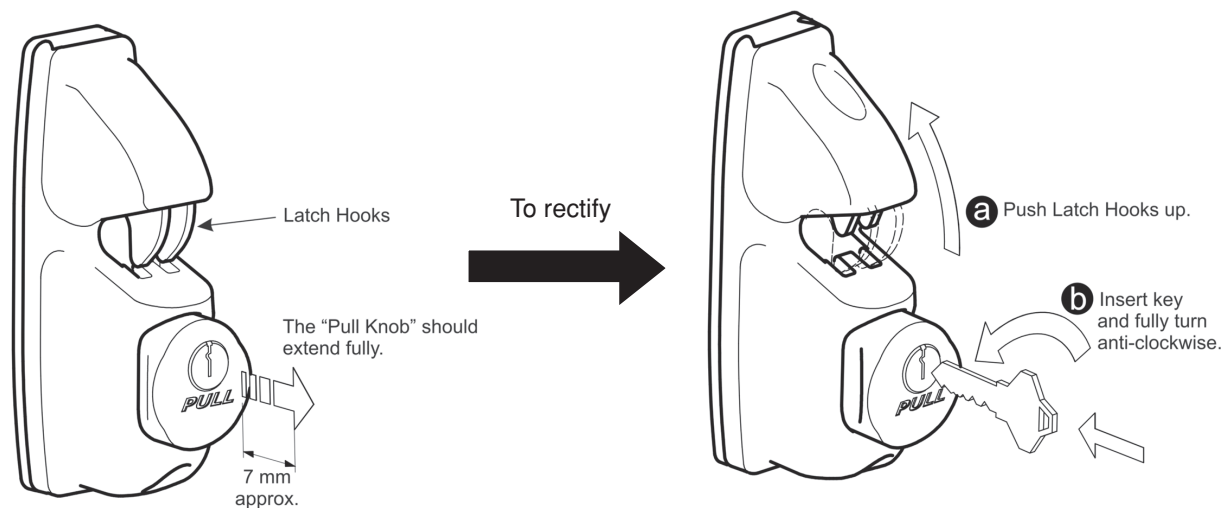

The operation of the Gate Latch may not be correct due to the key being turned whilst the *Latch Hooks* were reclined.

c It should now function correctly. Re-check operation.

LIMITED LIFETIME WARRANTY

Manufacturer's – Limited Lifetime Warranty (this "Warranty")

1. Subject to the conditions and limitations set out below, Safetech Hardware Australia Pty Ltd ACN 616 025 855 ("Safetech"), warrants that, for so long as the original purchaser of a product manufactured by Safetech owns that product (the "Product"), the Product will be free from all defects due to faulty design, materials or workmanship under normal use and service.
2. This Warranty is personal to the original purchaser of the Product, or to the first consumer where the Product has been purchased and installed by a contractor for the consumer's benefit, and is not transferable.
3. This Warranty does not apply in respect of defects due to or arising from:
 - a) normal wear and tear;
 - b) the failure to follow any procedures specified or recommended by Safetech for the installation, operation and maintenance of the Product including the use of petroleum based lubricants on the product at any time;
 - c) any act or circumstance beyond Safetech's control including tampering, unauthorised repairs or modifications, misuse, abuse, accident, damage in transit, damage caused by animals or natural events;
 - d) any defect of or in any material to which the Product is attached; or
 - e) the faulty workmanship of any person other than Safetech, including the installer of the Product.
4. To claim under this Warranty:
 - a) the purchaser must advise Safetech within 14 days of discovering a defect in the Product;
 - b) present acceptable proof of original ownership, e.g. original receipt, warranty card registration, online registration or other documentation that Safetech may deem acceptable; and
 - c) the purchaser must return the defective Product to Safetech or its agent, freight prepaid, together with proof of purchase.
5. Safetech will not, under this Warranty, be responsible for consequential damages (such as loss of use) inconvenience, loss or damage to personal property, whether direct, indirect or economic and whether arising in contract or tort. Under this Warranty Safetech's responsibility shall not exceed the purchase price of the component or its replacement.
6. Our goods come with guarantees that cannot be excluded under the Australian Consumer Law or any equivalent legislation within the applicable jurisdiction. You are entitled to a replacement or refund for a major failure and compensation for any other reasonably foreseeable loss or damage. You are also entitled to have the goods repaired or replaced if the goods fail to be of acceptable quality and the failure does not amount to a major failure.
7. Where a failure does not amount to a major failure, Safetech will provide, at Safetech's option a repair, replacement or refund for the hardware component of. If a product or component is no longer available and cannot be repaired, Safetech will, in its absolute discretion, replace the product with a substitute item.
8. The benefits to the purchaser given by this manufacturer's Warranty are in addition to all rights and remedies conveyed by the Competition and Consumer Act 2010 (Cth), or any equivalent legislation within the applicable jurisdiction, and any other statutory rights which the purchase may already be entitled and this Warranty does not exclude, restrict or modify any such rights or remedies implied by law.
9. No other express warranty or representation has been made or will be made on behalf of Safetech with respect to its hardware components, or the operation, repair or replacement of those components. No representative of Safetech or its distributors or retailers are authorised to make any changes or modifications to this Warranty.
10. Except for the limited warranty provided herein, to the extent permitted by law, Safetech disclaims all warranties, express or implied, including all warranties of merchantability and/or fitness for a particular purpose. To the extent that any implied warranties may nonetheless exist by operation of law, any such warranties are limited to the duration of this warranty.
11. Repair or replacement of the Product is the purchaser's exclusive remedy. Safetech shall not be liable for any special, incidental or consequential damages, including but not limited to lost revenues, lost profits, loss of data, rental of replacement equipment, damage to property, and third party claims arising out of any claim, either in contract, tort, and statute or otherwise. In no event will Safetech's entire liability exceed the purchase price of the Product.